

Butterworth LPF (5th order)

Page 11.18 Butterworth Active LPF EFDH
-3dB @ 15KHz

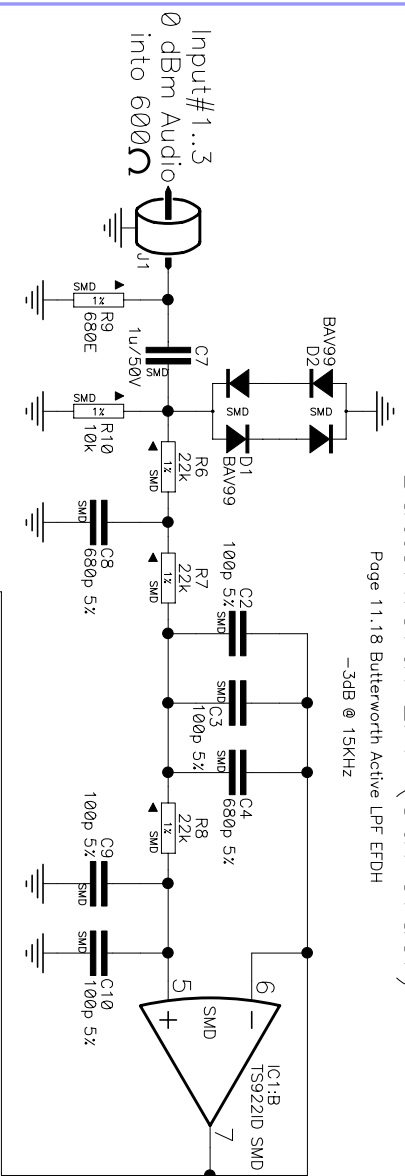

Audio Modulator by PE1RRT

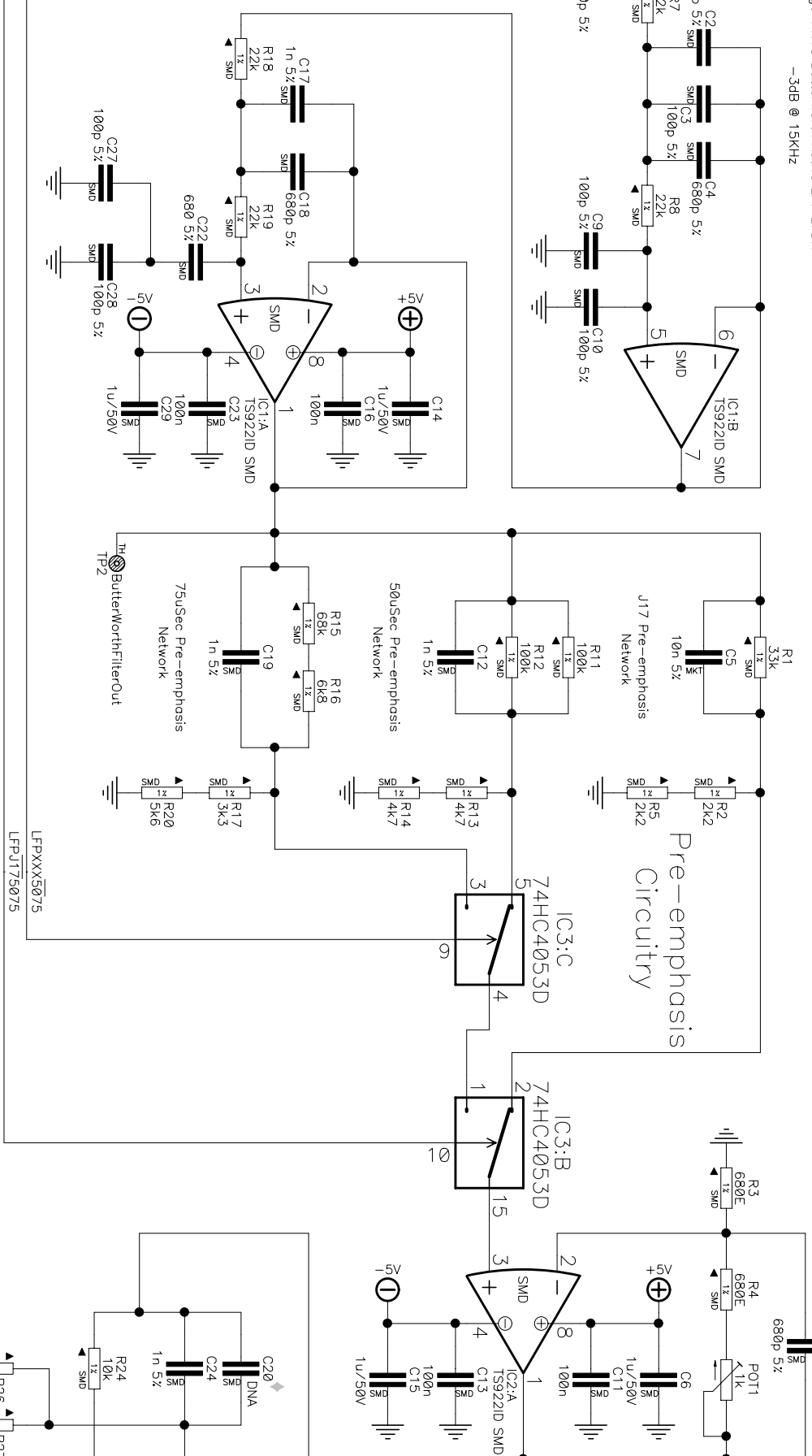

Double-T Notch Filter

Page 6.38 & 6.39 Active Notch EFDH
-30dB @ 15.625KHz

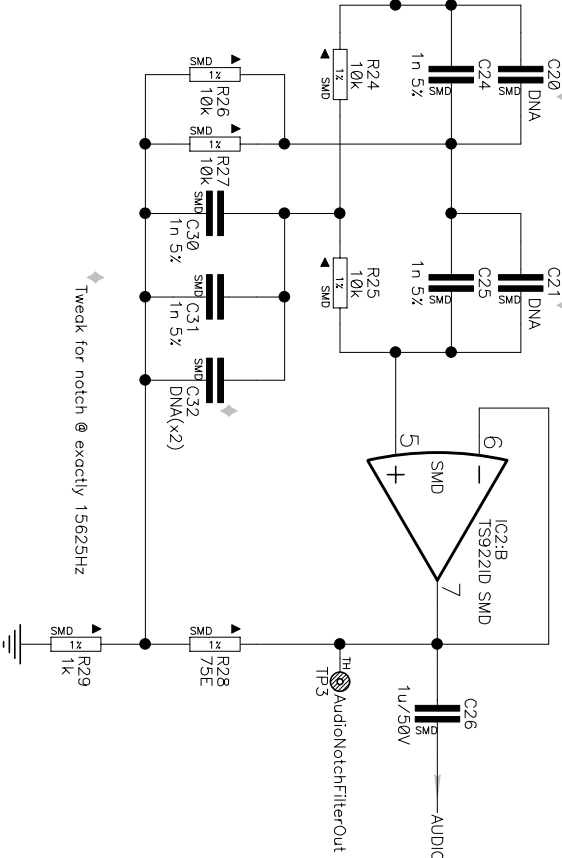

Control Port #1..#3

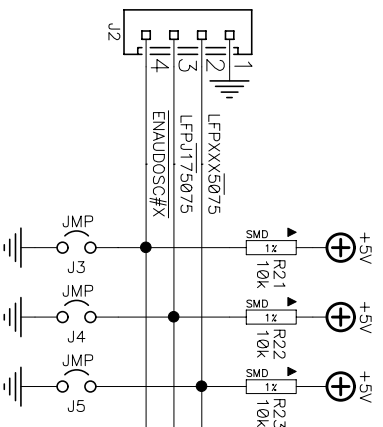

Audio Modulator #1..#3

5.5MHz, 6.5MHz, 7.5MHz

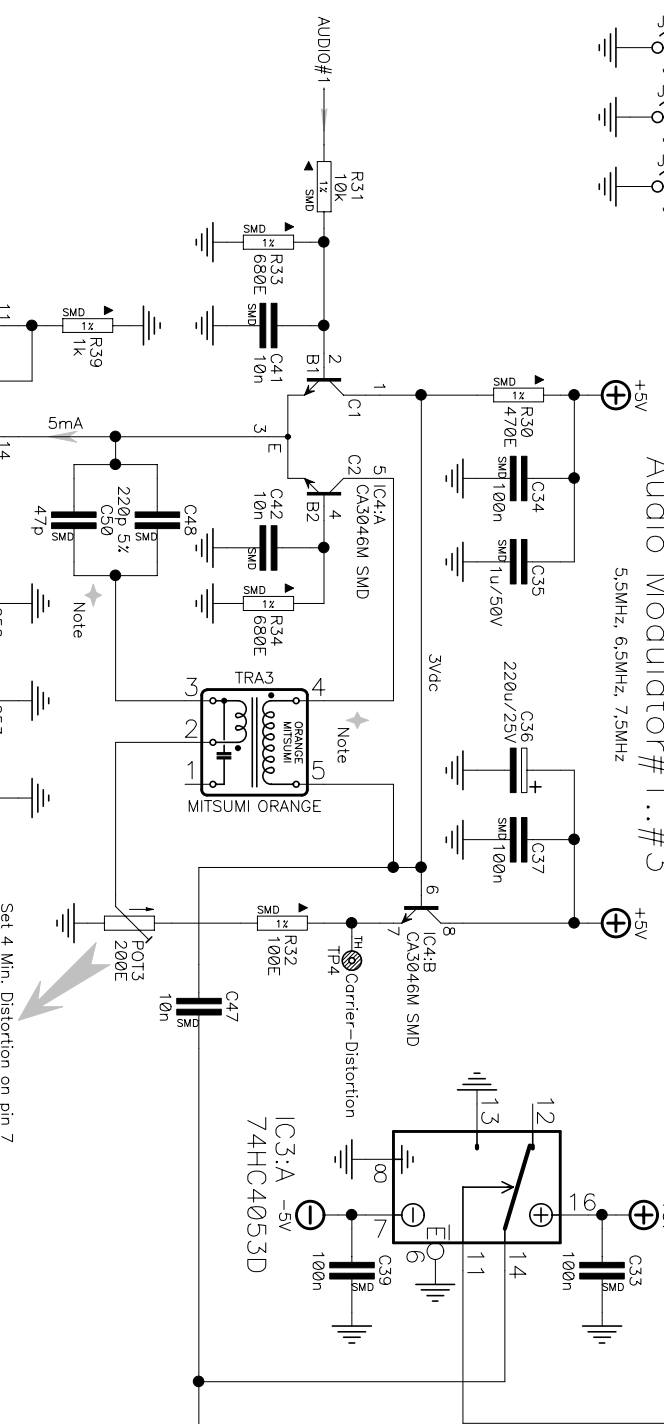

Chebyshev LPF (5th order)

Page 11.28 0.1dB ripple Chebyshev EFDH

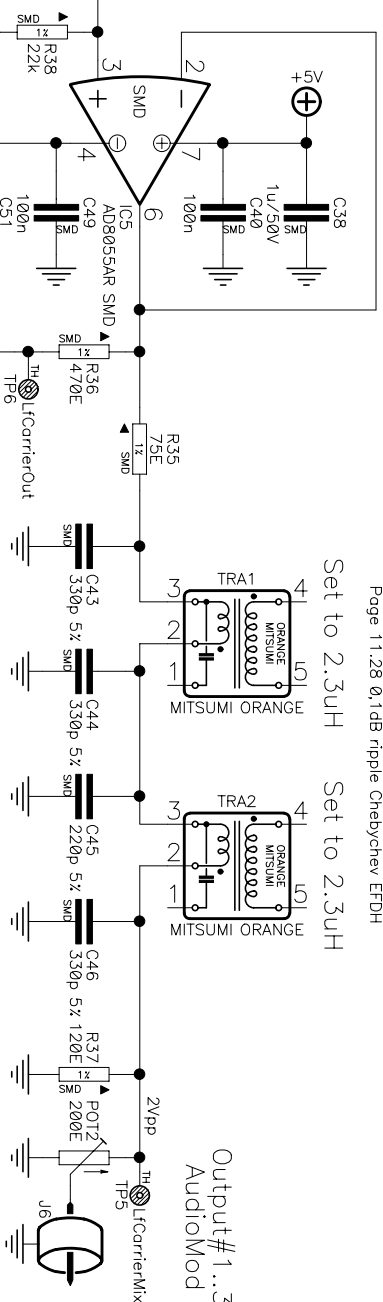

Set to 2.3uH Set to 2.3uH

Output#1..#3 AudioMod

- Set 4 Min. Distortion on pin 7
- Winding at pins 4 and 5 = 2 windings
- Set Audio Modulation frequency with Tra3.
- Only place capacitor C50 if needed.
- Styroflex or Silver-Mica are preferred here!

* EFDH = Electronic Filter Design Handbook (Williams/Taylor ISBN 0-07-070434-1)

CONFIDENTIAL DOCUMENT
This document is the private property of YIG Engineering B.V. and contains information of a highly sensitive and confidential nature. It is being divulged to you on the understanding that any improper disclosure will cause irreparable harm, which will be actionable by us against you.

YIG

Title: RRT's Video Baseband Audio Modulator #1..#3
Date: Dec 2002 Rev: X1
Drawn by: Marc Simons
Filename: AudioModulator.SCH
Sheet 1 of 2

Audio Modulator by PE1RRT

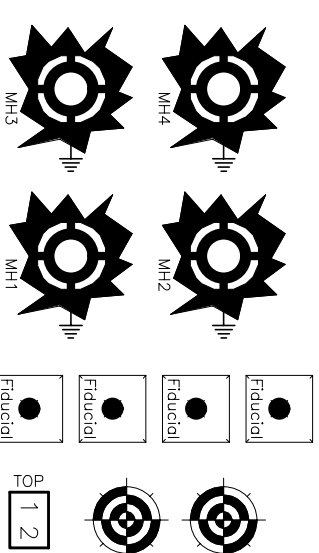
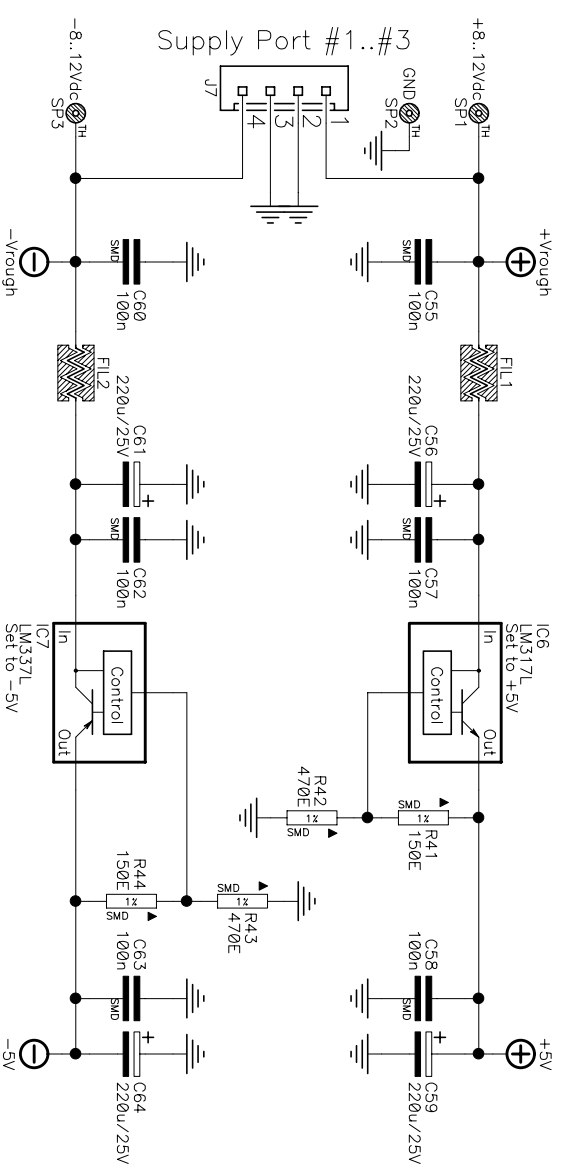

CONFIDENTIAL DOCUMENT

This document is the private property of YIG Engineering B.V. and contains information of a highly sensitive and confidential nature. It is being divulged to you on the understanding that any improper disclosure will cause irreparable harm, which will be actionable by us against you.

Title: RRT's Video Baseband
Audio Modulator Supply

Date: Dec 2002 Rev: X1
Filename: AudioModulator.SCH

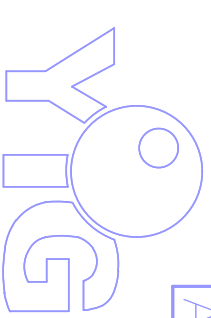

A4

Drawn by: Marc Simons
Sheet 2 of 2